

Max. oil flow will differ in case of a manifold with sequence function. Contact Dieseko Group for more information.

Specifications :		ICE 8RFB	
Eccentric moment	0 - 7.5 kgm	Clamps:	
Max. centrifugal force	0 - 435 kN	Sheet pile clamp	60TU
Max. frequency	2300 rpm	Transport weight per piece	250 kg
Max. amplitude excl. 60TU	15,2 mm	Double clamps	N/A
Max. amplitude incl. 60TU	12,1 mm	Transport weight per piece	N/A kg
Max. static line-pull	120 kN		
Max. pull-down	100 kN		
Max. operating pressure	350 bar	Powerpack:	
Max. oil flow	185 l/min	Model	N/A
Max. hydraulic power	108/147 kW/HP		
Forced lubrication	yes		
Dynamic weight excl. 60TU	985 kg	Hose set:	
Dynamic weight incl. 60TU	1235 kg	Length	N/A m
Total weight excl. 60TU & hoses	1515 kg	Transport weight (±)	N/A kg

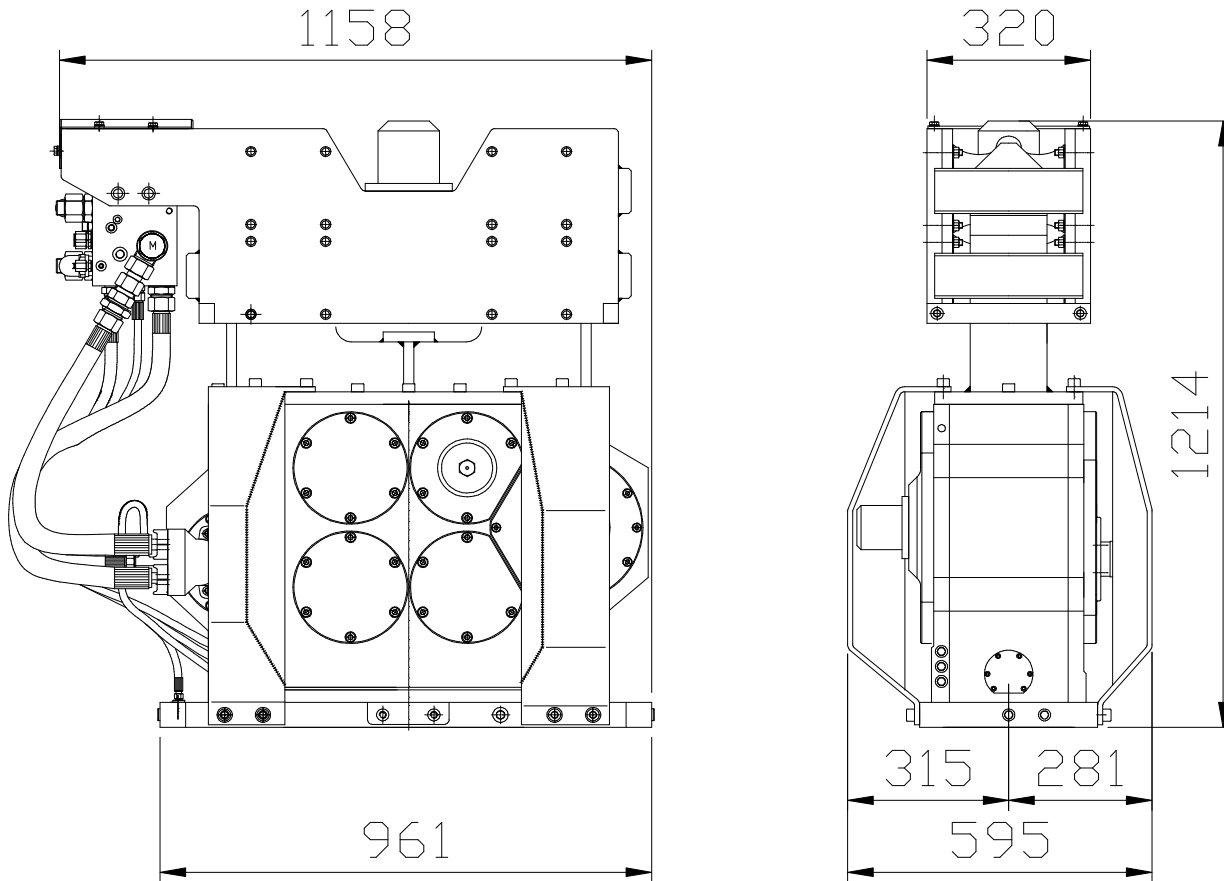

Bei einem Manifold mit Sequenzfunktion ist der maximale Fördermenge unterschiedlich. Kontaktieren Sie Dieseko Group für weitere Informationen.

Technische Daten :		ICE 8RFB	
Statisches Moment	0 - 7.5 kgm	Klemmzange:	
Max. Fliehkraft	0 - 435 kN	Universalzange	60TU
Max. Drehzahl	2300 rpm	Transportgew. pro Stück	250 kg
Max. Amplitude ohne 60TU	15,2 mm	Rohrklemmzange	N/A
Max. Amplitude mit 60TU	12,1 mm	Transportgew. pro Stück	N/A kg
Max. Statische Zugkraft	120 kN		
Max. Vorspannung	100 kN		
Max. Betriebsdruck	350 bar	Aggregat:	
Max. Fördermenge	185 l/min	Modell	N/A
Max. hydraulische Leistung	108/147 kW/PS		
Zwangsschmierung	ja		
Dyn. Gewicht ohne 60TU	985 kg	Schlauchsatz:	
Dyn. Gewicht mit 60TU	1235 kg	Länge	N/A m
Gesamtgew. ohne 60TU & Schläuche	1515 kg	Transportgewicht (±)	N/A kg

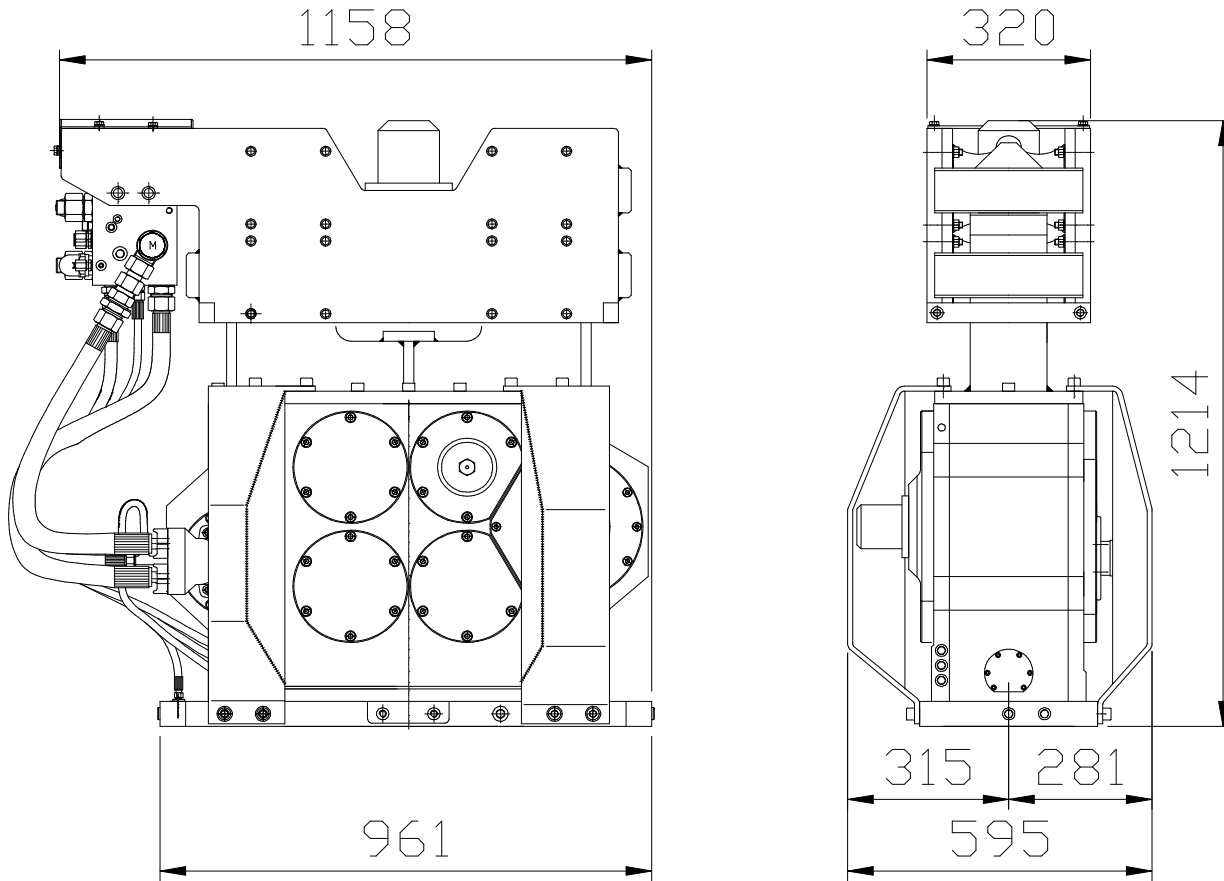

Le débit d'huile maximum sera différent dans le cas d'un manifold avec fonction de séquence. Contactez Dieseko Group pour plus d'informations.

Spécifications		ICE 8RFB	
Moment excentrique	0 - 7.5 kgm	Pinces:	
Max. force centrifuge	0 - 435 kN	Pince palplanche	60TU
Max. fréquence	2300 rpm	Poids de transport par pièce	250 kg
Max. amplitude sans 60TU	15,2 mm	Pince tube	N/A
Max. amplitude avec 60TU	12,1 mm	Poids de transport par pièce	N/A kg
Force de traction statique	120 kN		
Force maximale d'appui	100 kN		
Pression de travail max.	350 bar	Groupe hydraulique:	
Débit d'huile max.	185 l/min	Modèle	N/A
Puissance hydraulique max.	108/147 kW/ch		
Huile lubrifiante	oui		
Poids dynamique sans 60TU	985 kg	Jeu de tuyau:	
Poids dynamique avec 60TU	1235 kg	Longueur	N/A m
Poids total sans 60TU & tuyaux	1515 kg	Poids de transport (±)	N/A kg

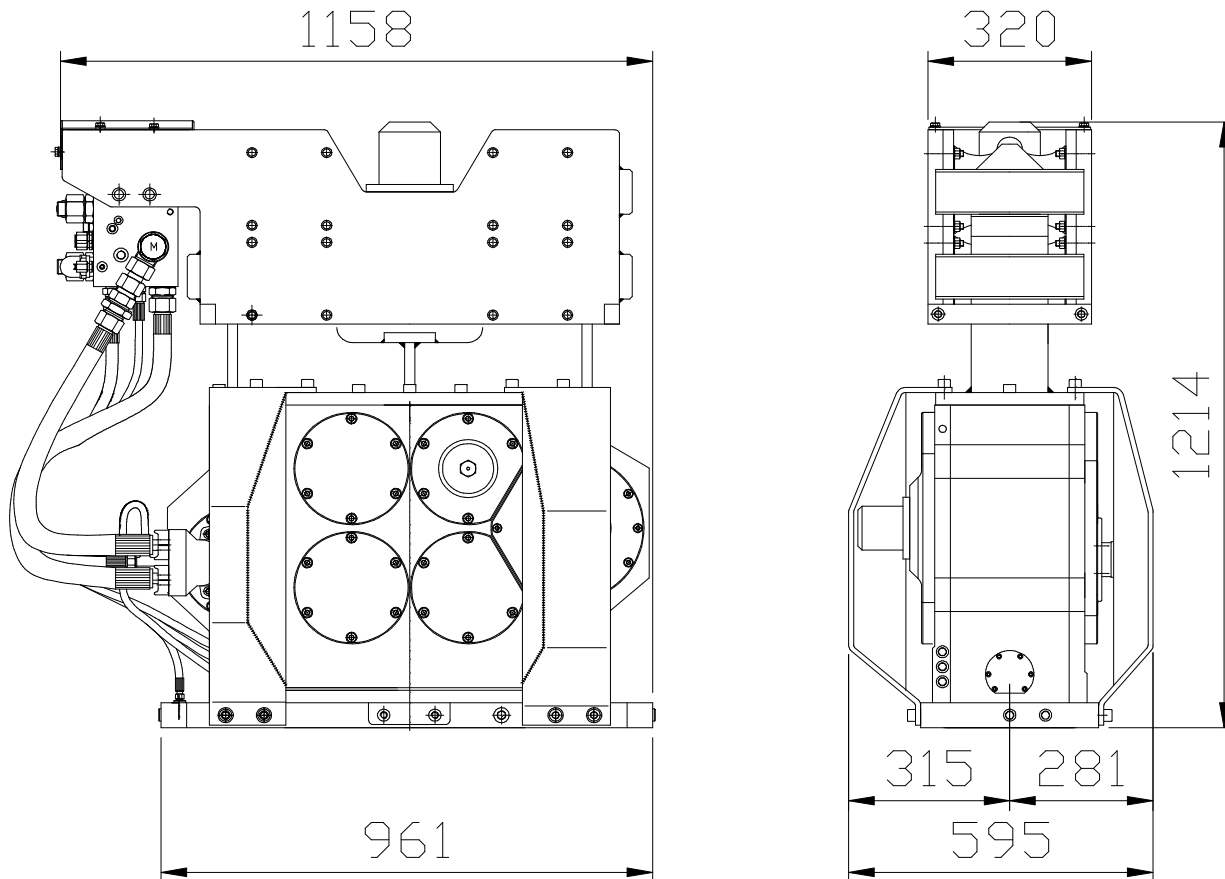

Max. oliestroom wijzigt in geval van manifold met volgordefunctie. Neem contact op met Dieseko Group voor meer informatie.

Specificaties		ICE 8RFB	
Excentrisch moment	0 - 7.5 kgm	Klemmen:	
Max. centrifugaalkracht	0 - 435 kN	Damwandklem	60TU
Max. toerental	2300 rpm	Transportgewicht per klem	250 kg
Max. amplitude excl. 60TU	15,2 mm	Pijpenklem	N/A
Max. amplitude incl. 60TU	12,1 mm	Transportgewicht per klem	N/A kg
Max. statische trekkracht	120 kN		
Max. voorspanning	100 kN		
Max. werkdruk	350 bar	Aggregaat:	
Max. oliedoorstroming	185 l/min	Model	N/A
Max. hydraulisch vermogen	108/147 kW/PK		
Geforceerde smering	ja		
Dynamisch gewicht excl. 60TU	985 kg	Slangenset:	
Dynamisch gewicht incl. 60TU	1235 kg	Lengte	N/A m
Totaalgewicht excl. 60TU & slangen	1515 kg	Transportgewicht (±)	N/A kg

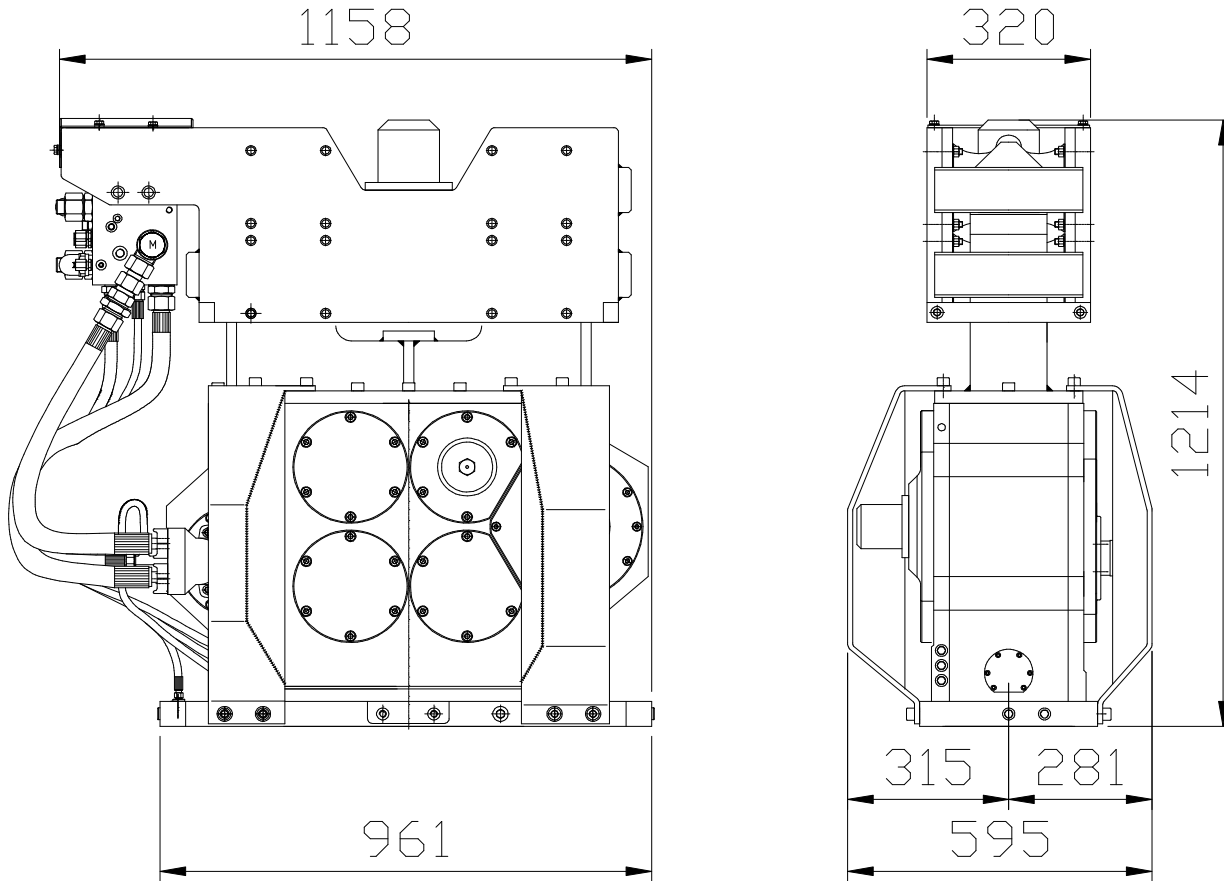

El flujo de aceite máximo diferirá con un colector con función de secuencia. Póngase en contacto con Dieseko Group para obtener más información.

Especificaciones		ICE 8RFB	
Momento excéntrico	0 - 7.5 kgm	Abrazadera:	
Fuerza centrífuga máxima	0 - 435 kN	Hoja abrazadera pila	60TU
Frecuencia máxima	2300 rpm	Peso de transporte por pieza	250 kg
Amplitud máxima excluyendo 60TU	15,2 mm	Abrazadera de tubo	N/A
Amplitud máxima incluyendo 60TU	12,1 mm	Peso de transporte por pieza	N/A kg
Estático tracción máxima	120 kN		
Compresión máxima	100 kN		
Presión máxima de trabajo	350 bar	Unidad de potencia:	
Flujo de aceite máximo	185 l/min	Modelo	N/A
Máxima potencia hidráulica	108/147 kW/HP		
Lubricación forzada	si		
Peso dinámico excluyendo 100TU	985 kg	Conjunto de manguera:	
Peso dinámico incluyendo 100TU	1235 kg	Longitud	N/A m
Peso total excluyendo 60TU & mangueras	1515 kg	Peso de transporte (±)	N/A kg

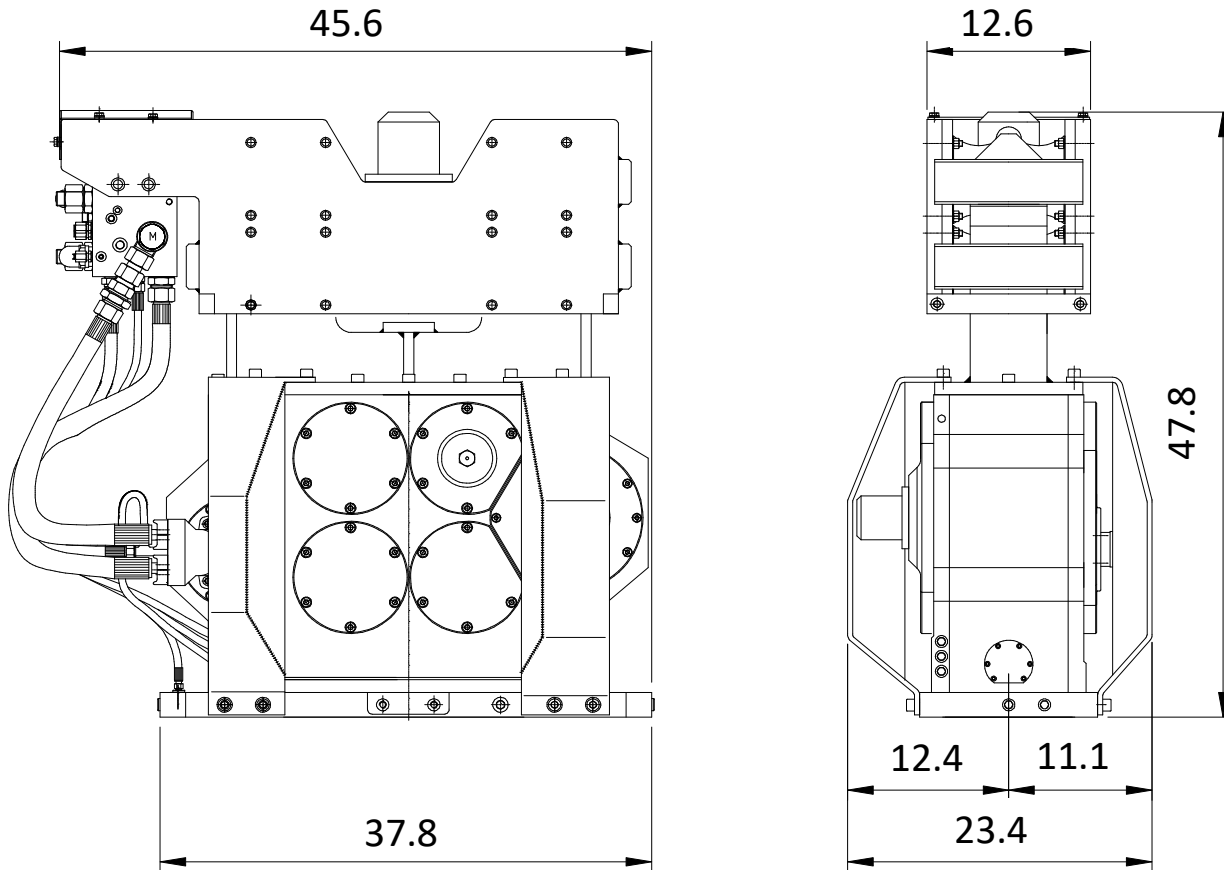

Max. oil flow will differ in case of a manifold with sequence function. Contact Dieseko Group for more information.

Specifications		ICE 8RFB	
Eccentric moment	0-651 in-lbs	Clamps:	
Max. centrifugal force	0-49 ton	Sheet pile clamp	60TU
Max. frequency	2,300 rpm	Transport weight per piece	551 lbs
Max. amplitude excluding 60TU	0.6 in	Double clamps	N/A
Max. amplitude including 60TU	0.48 in	Transport weight per piece	N/A lbs
Max. static line-pull	12 ton		
Max. pull-down	10 ton		
Max. operating pressure	5,076 psi	Powerpack:	
Max. oil flow	49 gal/min	Model	N/A
Max. hydraulic power	108/147 kW/HP		
Forced lubrication	yes		
Dynamic weight excluding 60TU	2,172 lbs	Hose set:	
Dynamic weight including 60TU	2,723 lbs	Length	N/A ft
Total weight excluding 60TU & hoses	3,340 lbs	Transport weight (±)	N/A lbs

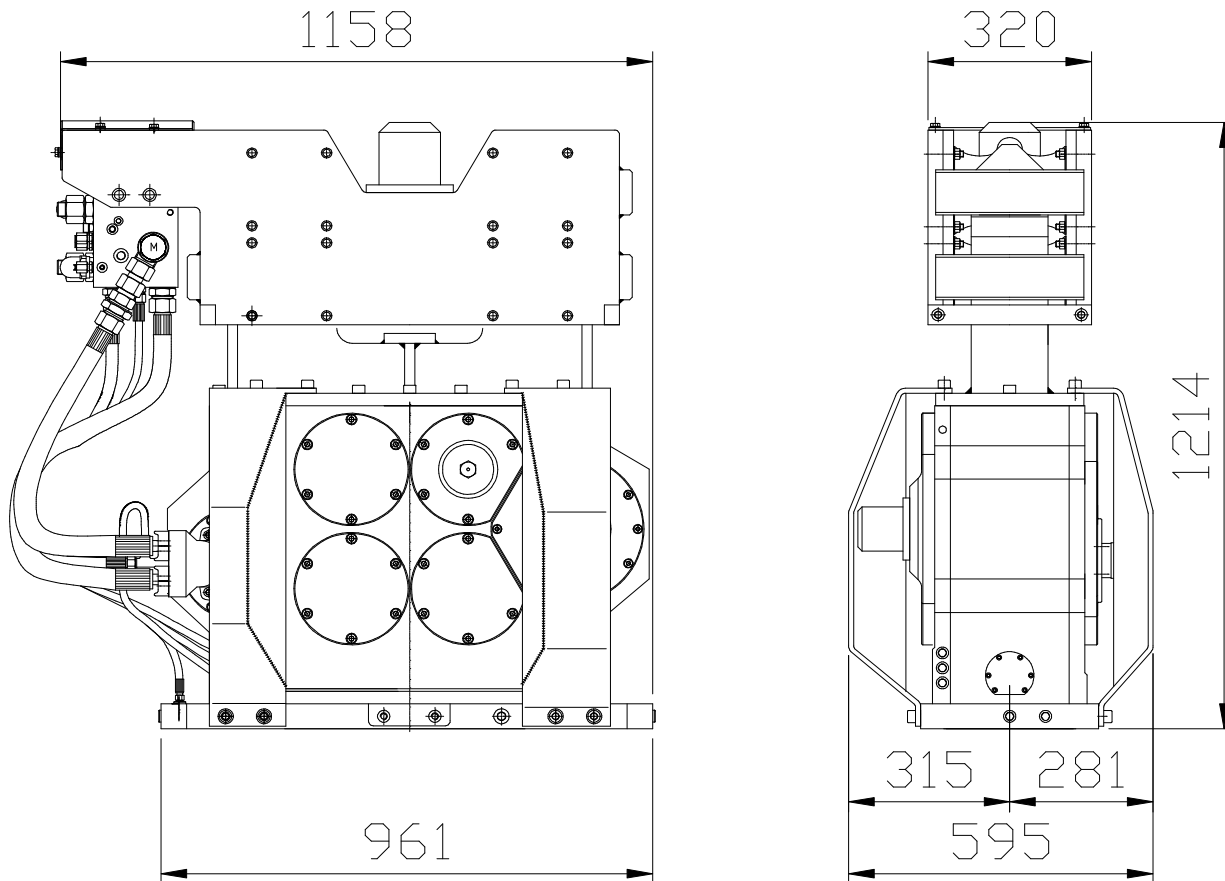

Debitul maxim de ulei va fi diferit în cazul unui colector cu funcție de secvență. Contactați Dieseko Group pentru mai multe informații.

Specificatii :		ICE 8RFB	
Moment excentric	0 - 7.5 kgm	menghira:	
Forta centrifuga maxima	0 - 435 kN	menghina pentru palpanse	60TU
Frecventa maxima	2300 rpm	Greutatea de transport pp.	250 kg
Amplitudine maxima exclusiva. 60TU	15,2 mm	menghina dubla	N/A
Amplitudine maxima inclusivă. 60TU	12,1 mm	Greutatea de transport pp.	N/A kg
Tractiune maxima statica	120 kN		
Trage în jos maxima	100 kN		
Presiune maxima de lucru	350 bar	generatoare:	
Debit maxim de ulei	185 l/min	Model	N/A
Puterea hidraulică maxima	108/147 kW/HP		
Lubrifiere fortata	da		
Greutatea dinamica exclusiva. 60TU	985 kg	Tip de furtun:	
Greutatea dinamica inclusivă. 60TU	1235 kg	Lungimea	N/A m
Greutatea totala fara. 60TU si furtun	1515 kg	Greutatea de transport (±)	N/A kg