



Specification sheet

PVE 150M

Vibro Hammer

English

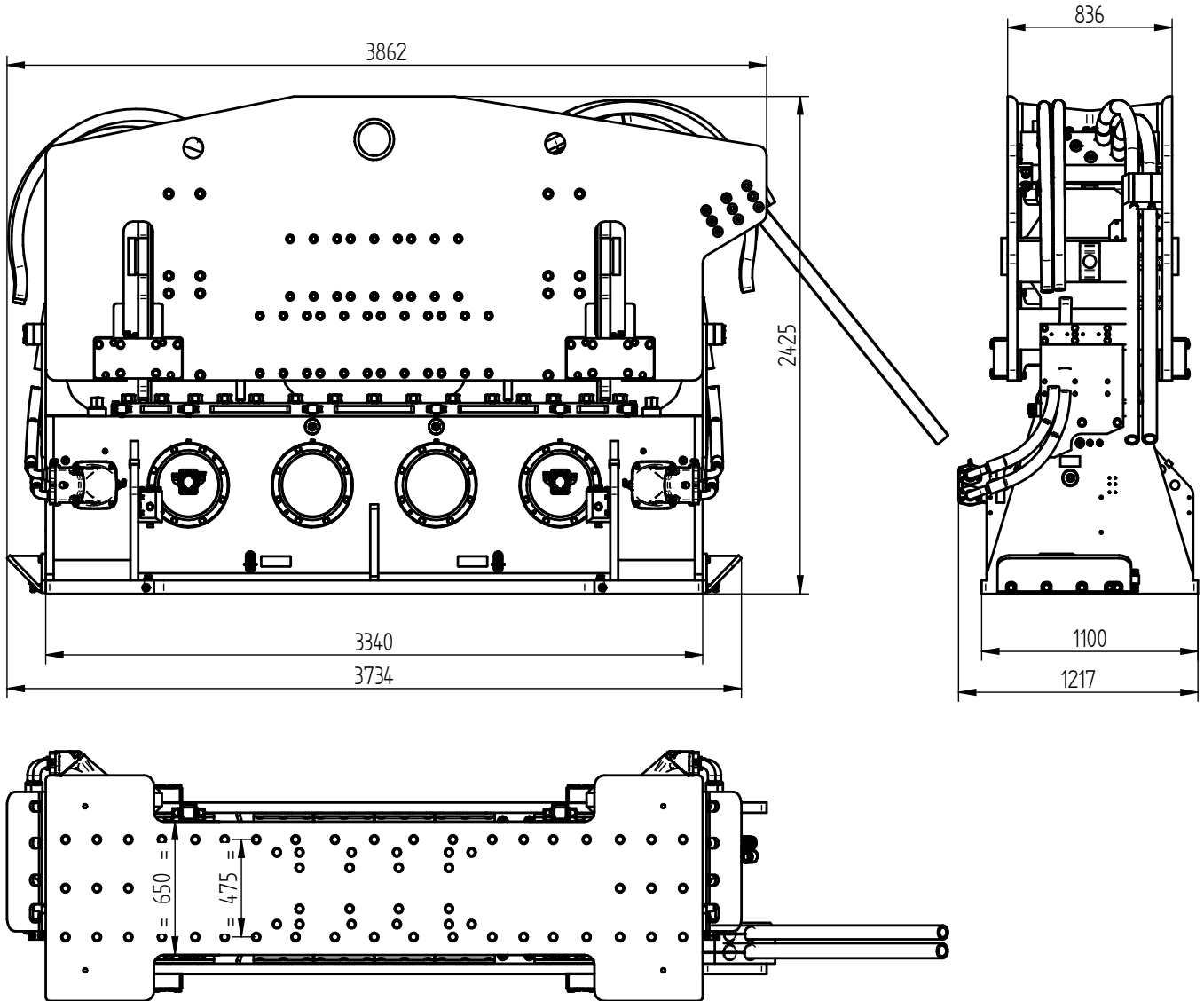

Specifications :

PVE 150M

Eccentric moment	150 kgm	Clamps:	
Centrifugal force	3224 kN	Double clamps	200TC
Max. frequency	1400 rpm	Transport weight per piece	1350 kg
Max. amplitude excl. 200TC (2x)	26,3 mm		
Max. amplitude incl. 200TC (2x)	21,3 mm		
Max. static line-pull	1260 kN		
Max. pull-down	120 kN		
Max. operating pressure	350 bar	Powerpack:	
Max. oil flow	1293 l/min	Model	1400 series
Max. hydraulic power	754/1025 kW/HP		
Forced lubrication	yes		
Dynamic weight excl. 200TC (2x)	11400 kg	Hose set:	
Dynamic weight incl. 200TC (2x)	14100 kg	Length	60 m
Total weight excl. 200TC (2x) & hoses	17780 kg	Transport weight (±)	1640 kg

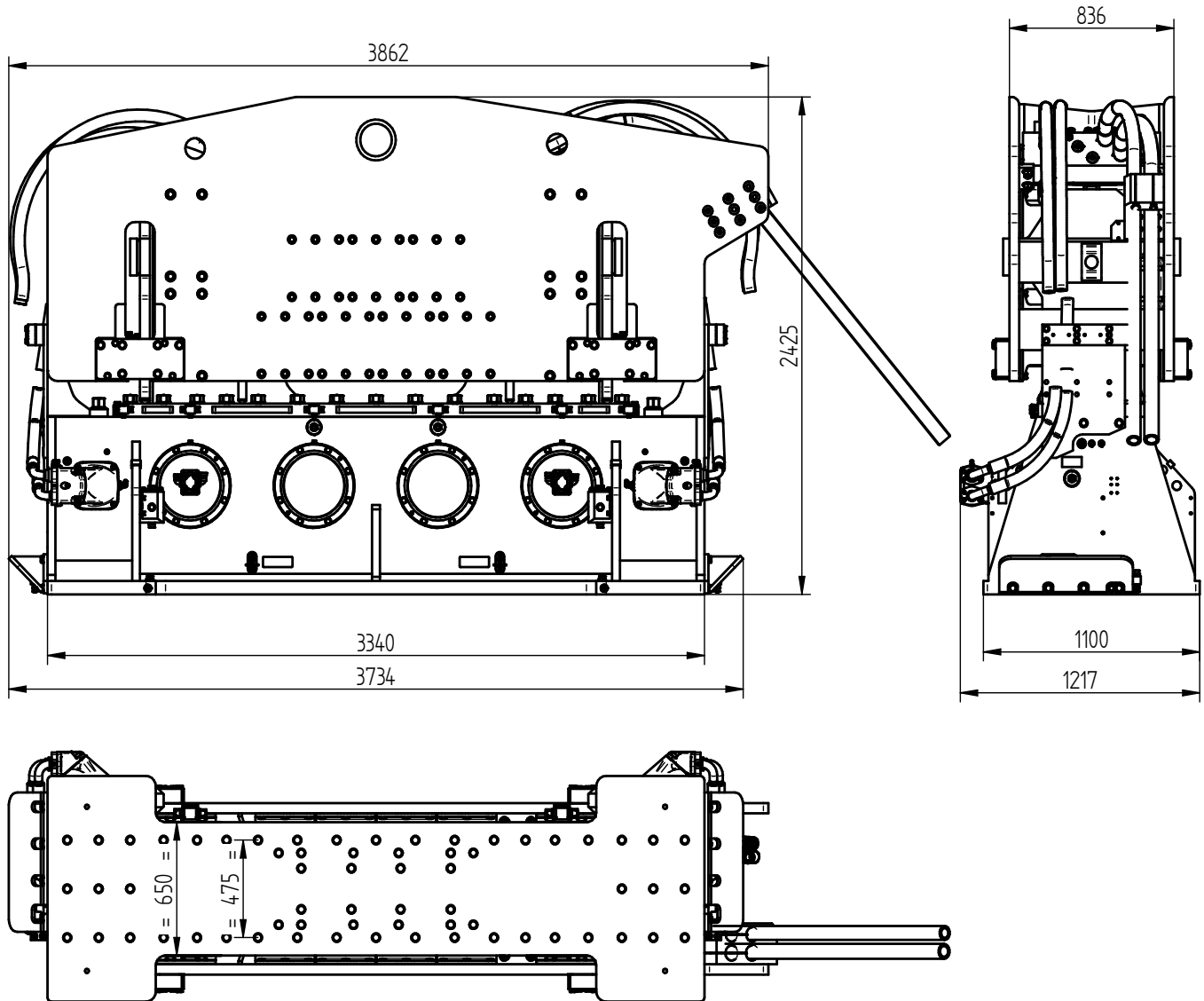

Technische Daten :

PVE 150M

Statisches Moment	150 kgm	Klemmzange:	
Max. Fliehkraft	3224 kN	Rohrklemmzange	200TC
Max. Drehzahl	1400 rpm	Transportgew. pro Stück	1350 kg
Max. Amplitude ohne 200TC (2x)	26,3 mm		
Max. Amplitude mit 200TC (2x)	21,3 mm		
Max. Statische Zugkraft	1260 kN		
Max. Vorspannung	120 kN		
Max. Betriebsdruck	350 bar	Aggregat:	
Max. Fördermenge	1293 l/min	Modell	1400 series
Max. hydraulische Leistung	754/1025 kW/PS		
Zwangsschmierung	ja		
Dyn. Gewicht ohne 200TC (2x)	11400 kg	Schlauchsatz:	
Dyn. Gewicht mit 200TC (2x)	14100 kg	Länge	60 m
Gesamtgew. ohne 200TC (2x) & Schläuche	17780 kg	Transportgewicht (±)	1640 kg



Spécifications

PVE 150M

Vibro Hammer

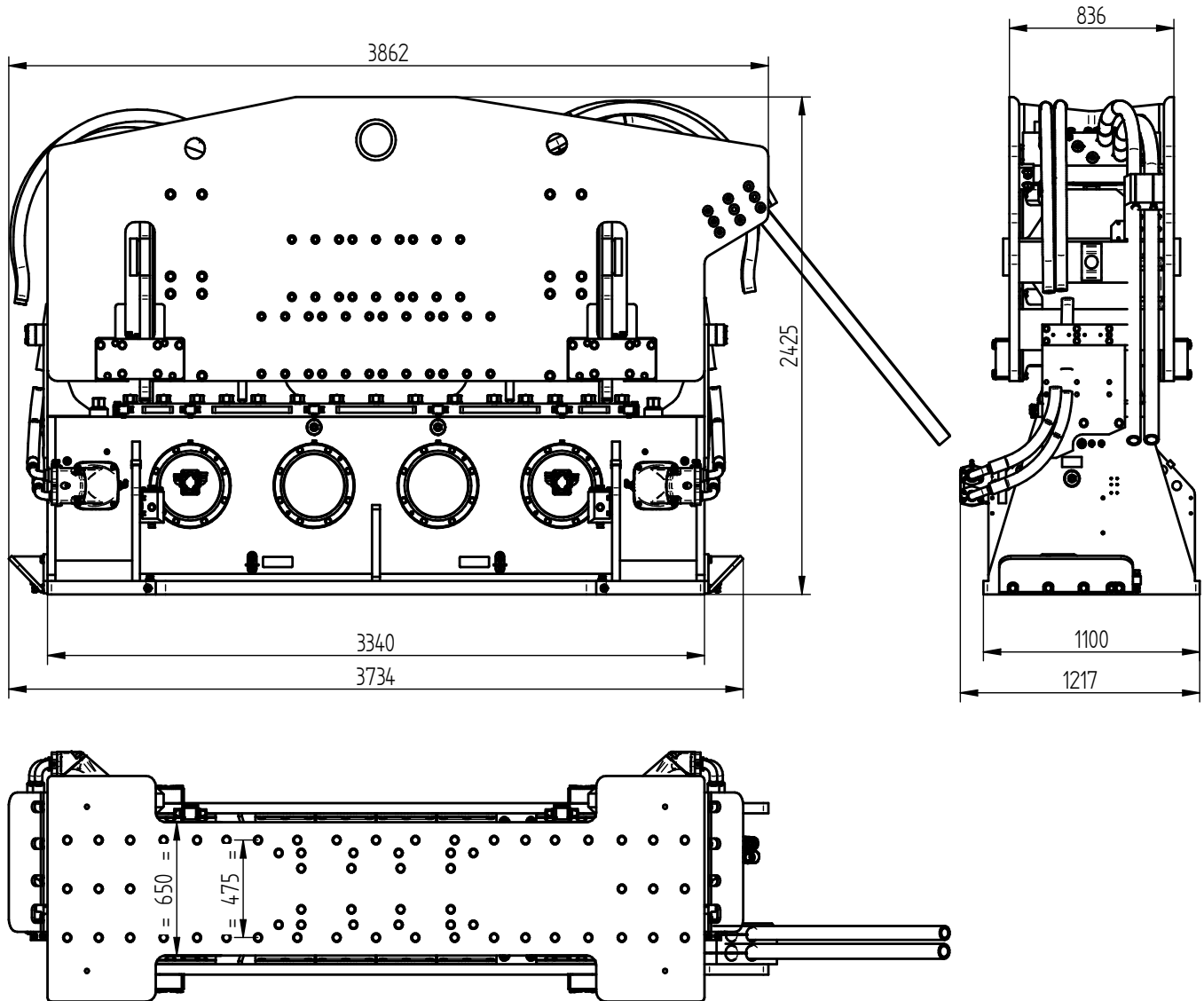

Spécifications		PVE 150M	
Moment excentrique	150 kgm	Pinces:	
Max. force centrifuge	3224 kN	Pince tube	200TC
Max. fréquence	1400 rpm	Poids de transport par pièce	1350 kg
Max. amplitude sans 200TC (2x)	26,3 mm		
Max. amplitude avec 200TC (2x)	21,3 mm		
Force de traction statique	1260 kN		
Force maximale d'appui	120 kN		
Pression de travail max.	350 bar	Groupe hydraulique:	
Débit d'huile max.	1293 l/min	Modèle	1400 series
Puissance hydraulique max.	754/1025 kW/ch		
Huile lubrifiante	oui		
Poids dynamique sans 200TC (2x)	11400 kg	Jeu de tuyau:	
Poids dynamique avec 200TC (2x)	14100 kg	Longueur	60 m
Poids total sans 200TC (2x) & tuyaux	17780 kg	Poids de transport (±)	1640 kg

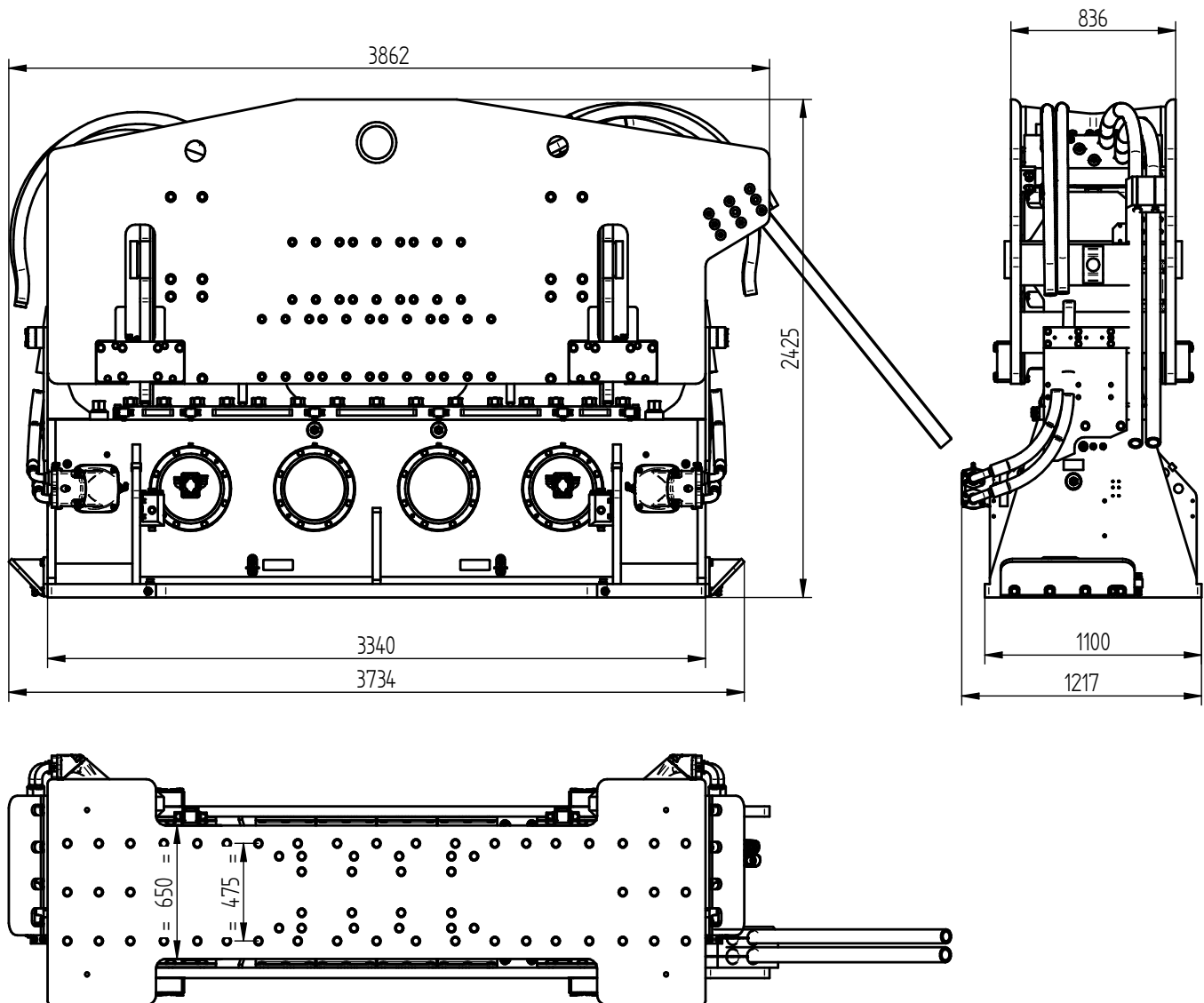

Specificaties		PVE 150M	
Excentrisch moment	150 kgm	Klemmen:	
Max. centrifugaalkracht	3224 kN	Pijpenklem	200TC
Max. toerental	1400 rpm	Transportgewicht per klem	1350 kg
Max. amplitude excl. 200TC (2x)	26,3 mm		
Max. amplitude incl. 200TC (2x)	21,3 mm		
Max. statische trekkracht	1260 kN		
Max. voorspanning	120 kN		
Max. werkdruk	350 bar	Aggregaat:	
Max. oliedoorstroming	1293 l/min	Model	1400 series
Max. hydraulisch vermogen	754/1025 kW/PK		
Geforceerde smering	ja		
Dynamisch gewicht excl. 200TC (2x)	11400 kg	Slangenset:	
Dynamisch gewicht incl. 200TC (2x)	14100 kg	Lengte	60 m
Totaalgewicht excl. 200TC (2x) & slangen	17780 kg	Transportgewicht (±)	1640 kg

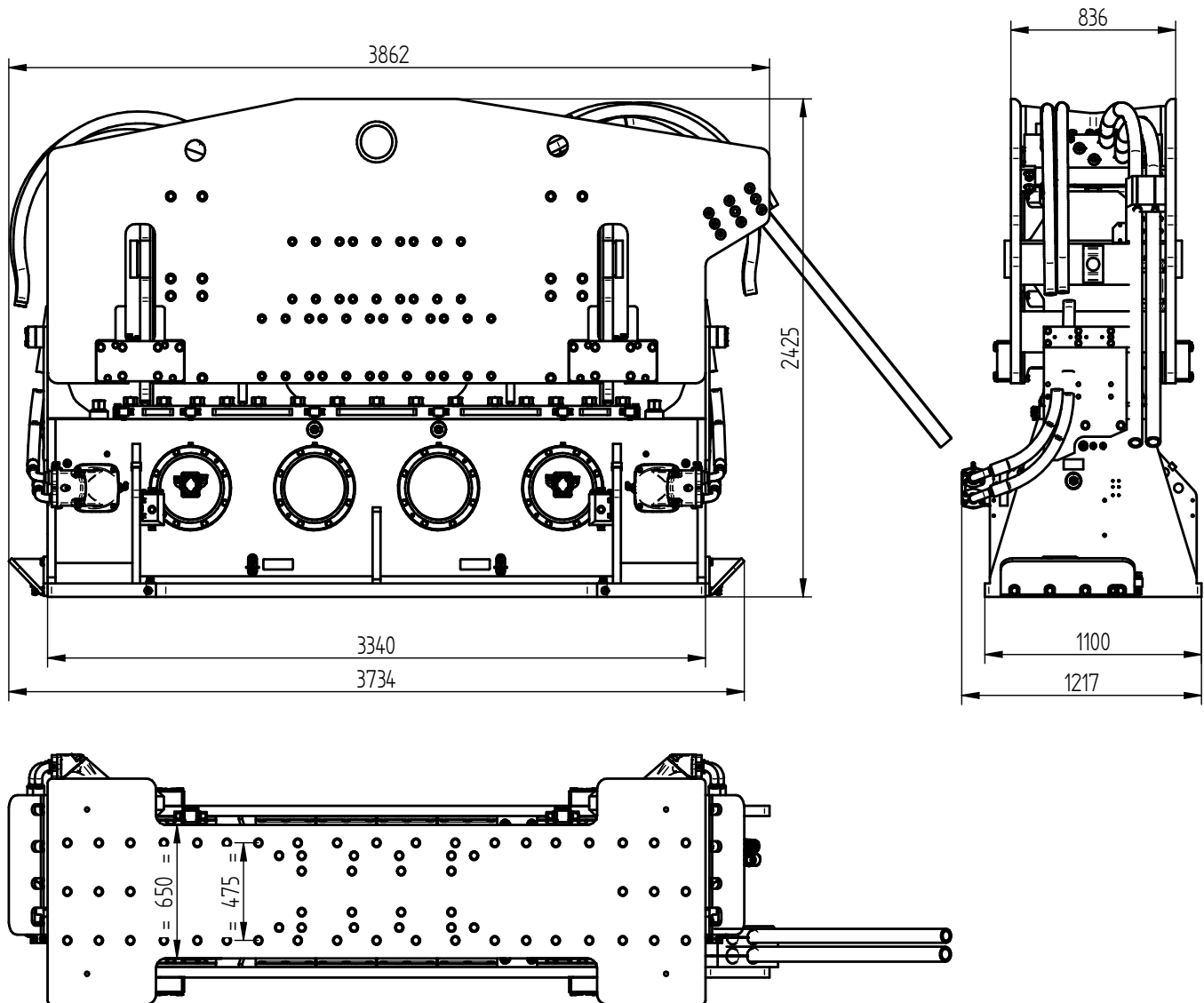

Especificaciones		PVE 150M	
Momento excéntrico	150 kgm	Abrazadera:	
Fuerza centrífuga máxima	3224 kN	Abrazadera de tubo	200TC
Frecuencia máxima	1400 rpm	Peso de transporte por pieza	1350 kg
Amplitud máxima excluyendo 200TC (2x)	26,3 mm		
Amplitud máxima incluyendo 200TC (2x)	21,3 mm		
Estático tracción máxima	1260 kN		
Compresión máxima	120 kN		
Presión máxima de trabajo	350 bar	Unidad de potencia:	
Flujo de aceite máximo	1293 l/min	Modelo	1400 series
Máxima potencia hidráulica	754/1025 kW/HP		
Lubricación forzada	si		
Peso dinámico excluyendo 200TC (2x)	11400 kg	Conjunto de manguera:	
Peso dinámico incluyendo 200TC (2x)	14100 kg	Longitud	60 m
Peso total excluyendo 200TC (2x) & mangueras	17780 kg	Peso de transporte (±)	1640 kg



Specifications

PVE 150M

Vibro Hammer

USA

Dimensions in inches

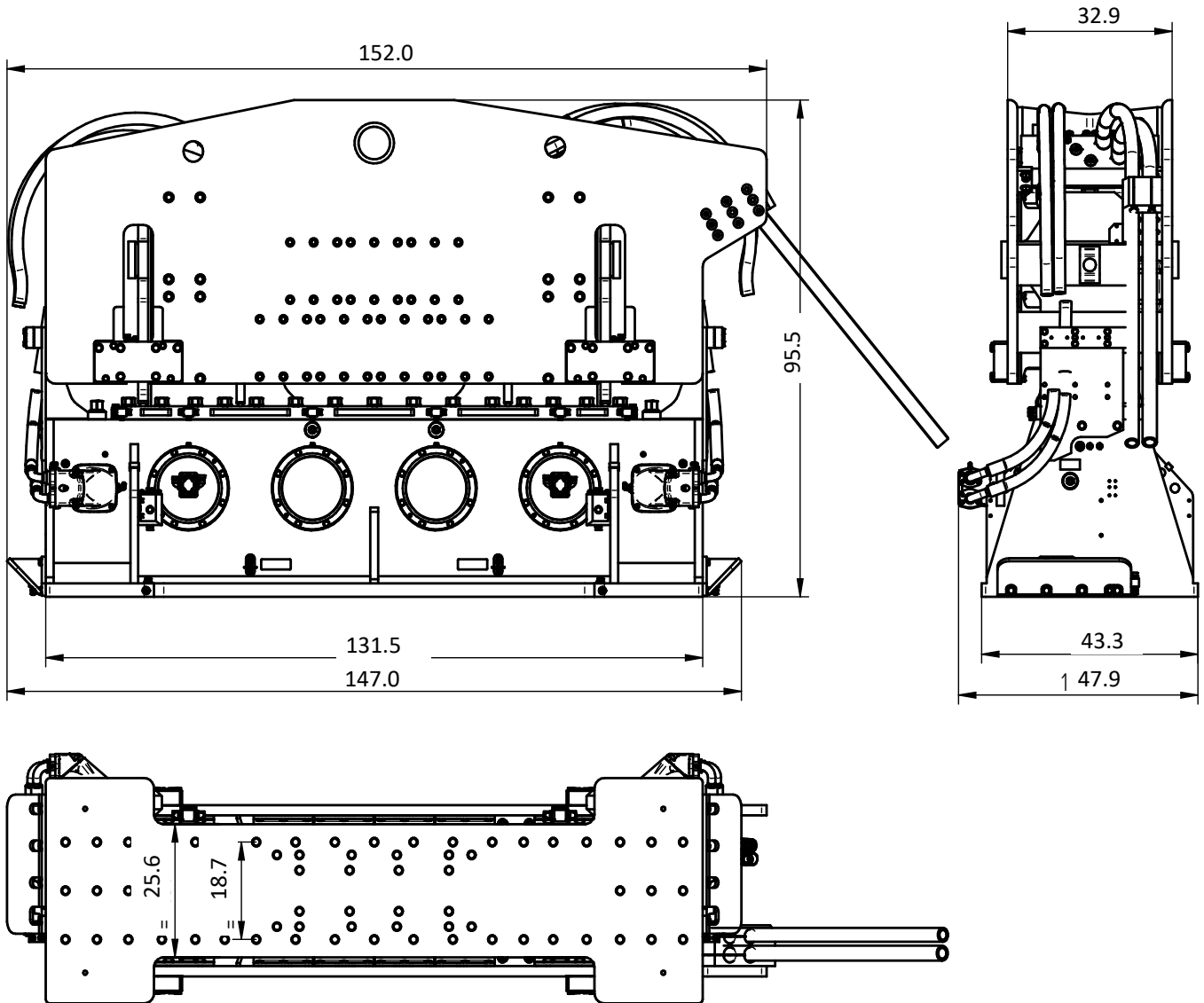

Specifications		PVE 150M	
Eccentric moment	13,021 in-lbs	Clamps:	
Centrifugal force	362 ton	Double clamps	200TC
Max. frequency	1,400 rpm	Transport weight per piece	2,976 lbs
Max. amplitude excluding 200TC (2x)	1.04 in		
Max. amplitude including 200TC (2x)	0.84 in		
Max. static line-pull	142 ton		
Max. pull-down	13 ton		
Max. operating pressure	5,076 psi	Powerpack:	
Max. oil flow	342 gal/min	Model	1400 series
Max. hydraulic power	754/1025 kW/HP		
Forced lubrication	yes		
Dynamic weight excluding 200TC (2x)	25,133 lbs	Hose set:	
Dynamic weight including 200TC (2x)	31,085 lbs	Length	197 ft
Total weight excluding 200TC (2x) & hoses	39,198 lbs	Transport weight (±)	3616 lbs

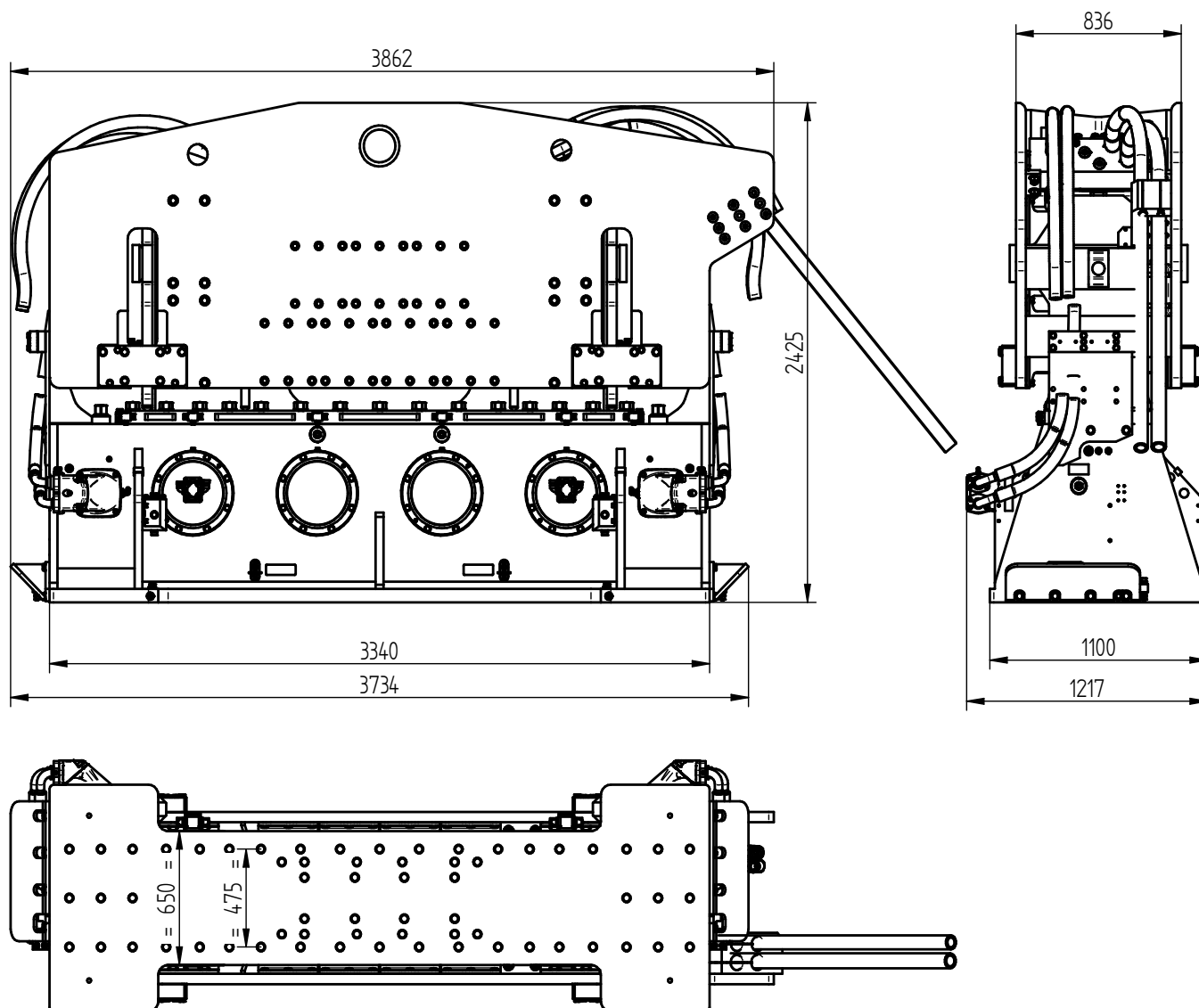
Specificatii :
PVE 150M

Moment excentric	150 kgm	menghira:	
Forta centrifuga maxima	3224 kN	menghina dubla	200TC
Frecventa maxima	1400 rpm	Greutatea de transport pp.	1350 kg
Amplitudine maxima exclusiva. 200TC (2x)	26,3 mm		
Amplitudine maxima inclusivă. 200TC (2x)	21,3 mm		
Tractiune maxima statica	1260 kN		
Trage în jos maxima	120 kN		
Presiune maxima de lucru	350 bar	generatoare:	
Debit maxim de ulei	1293 l/min	Model	1400 series
Puterea hidraulică maxima	754/1025 kW/HP		
Lubrifiere fortata	da		
Greutatea dinamica exclusiva. 200TC (2x)	11400 kg	Tip de furtun:	
Greutatea dinamica inclusivă. 200TC (2x)	14100 kg	Lungimea	60 m
Greutatea totala fara. 200TC (2x) si furtun	17780 kg	Greutatea de transport (±)	1640 kg